



Bringing clean air to life:

High Purity Filtration Solutions

Cleanroom Components

AstroFan FFU® High Efficiency HEPA/ULPA FFU

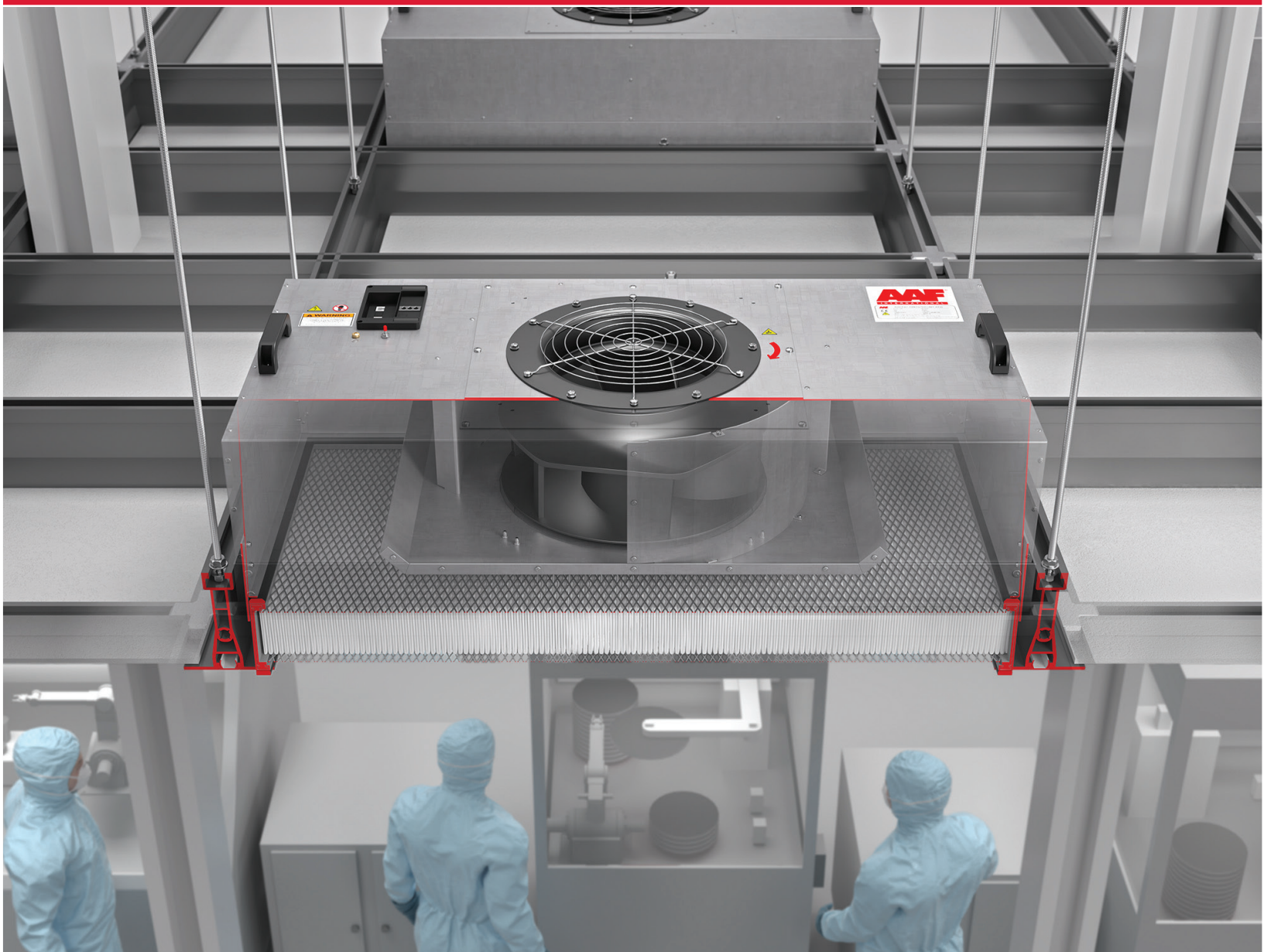

AstroFan FFU

ASTROFAN FAN FILTER UNIT

Product description

The AstroFan FFU module comprises of an aluminium housing (2,0 mm) containing a high performance encapsulated AAF Optimized direct driven backward curved EC fan/motor combination and a replaceable AAF HEPA or ULPA filter.

The entire housing is easy to decontaminate and resistant to disinfectants. The housing seals and rests on the anodized aluminium extrusions of the AAF HEPA or ULPA filter. The 14 mm flat flange of the filter rests on the dry gasket, applied into the ceiling grid.

Reduced energy consumption and less noise thanks to AAF Optimized fan design.

AAF centrifugal fans with backward-curved blades are the new standard in ventilation and air-conditioning. AAF Fans include both noise minimization and a further decrease in energy consumption. The optimized impeller with backward-curved blades is made of fiberglass-reinforced plastic, enabling an aerodynamically optimized shape that cuts the noise level in half and reduces power requirements significantly.

The ideal solution to minimize your planned and unplanned cleanroom downtime costs by offering:

- More Flexibility
- More Safety
- More Convenience
- More Cost Savings
- More Reliability

Features and Benefits

- Available in 7 standard sizes
- Lightweight aluminium housing
- Low sound level
- Suitable for all ISO cleanroom classes
- Suitable for turbulent and laminar flow
- Suitable for a wide range of AAF HEPA and ULPA filters
- Available with EC RS-485, 0-10 Volt and MODBUS RTU control interface



Note: AstroFan FFU 1212 displayed without installed filter.

Applications

The AAF AstroFan Filter Unit (FFU) is a self-contained ceiling fan filter module, designed for use in turbulent mixing and laminar airflow cleanroom areas. The unit is designed for utilization in the AAF 50 mm, 55 mm T-Bar ceiling grid, the AstroDry HD ceiling grid and compatible ceiling grids. The lightweight unit is easy to install. Typical applications include cleanrooms ISO.EN 14644-1, Class 5 (Class M 3.5 (100) to US Federal Standard 209E).

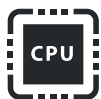

Microelectronics



Pharmaceuticals



Aerospace



Optics



Medical devices



Healthcare



Food & Beverage

Technical data

Nominal Size	FFU 66	FFU 69	FFU 612	FFU 612 SL	FFU 912	FFU 1212
Airflow m³/h	520	800	1080	1080	1650	2220
Actual dimensions L x W [mm]	570 x 570	570 x 870	570 x 1170	570 x 1170	870 x 1170	1170 x 1170
Height including filter¹ [mm]	445	445	445	275	445	445
Extra height for a RSC execution	30	30	30	30	30	30
Power supply	220 - 240V 1 Phase 50/60 Hz	220 - 240V 1 Phase 50/60 Hz	220 - 240V 1 Phase 50/60 Hz	220 - 240V 1 Phase 50/60 Hz	220 - 240V 1 Phase 50/60 Hz	220 - 240V 1 Phase 50/60 Hz
Power consumption EBM Bus	0,41 kW	0,41 kW	0,32 kW	0,29 kW	0,32 kW	0,32 kW
Power consumption MOD Bus RTU	0,50 kW	0,50 kW	0,50 kW	0,47 kW	0,50 kW	0,50 kW
Weight including filter	22 kg	24 kg	31 kg	28 kg	47 kg	59 kg
Fan resistance (Pa)	600	590	370	580	345	300
Sound Pressure Level at 0,45 m/s (dB(A))	49	45	44	55	47	55
Filter Media Types	Glassfiber / Membrane					
Efficiency	H13 to U17					
Installation Options	Top side / Roomside change frame / Roomside change grid					
Accessories	Coolong Coils / Prefilter / AMC Filter / Diffuser / Test port					
Control Platform	PC / PLC / IoT / Manual					

Note 1. The AstroFan FFU 612 SL includes for a 2" filter (50 mm pack). All others have a 3" (72 mm media pack).

Note 2. Power consumption is based on EBM Bus motors.

Adaptation to local conditions

AAF has dedicated software to determine the exact working point of the AstroFan FFU in the installation. Please contact AAF for more information.

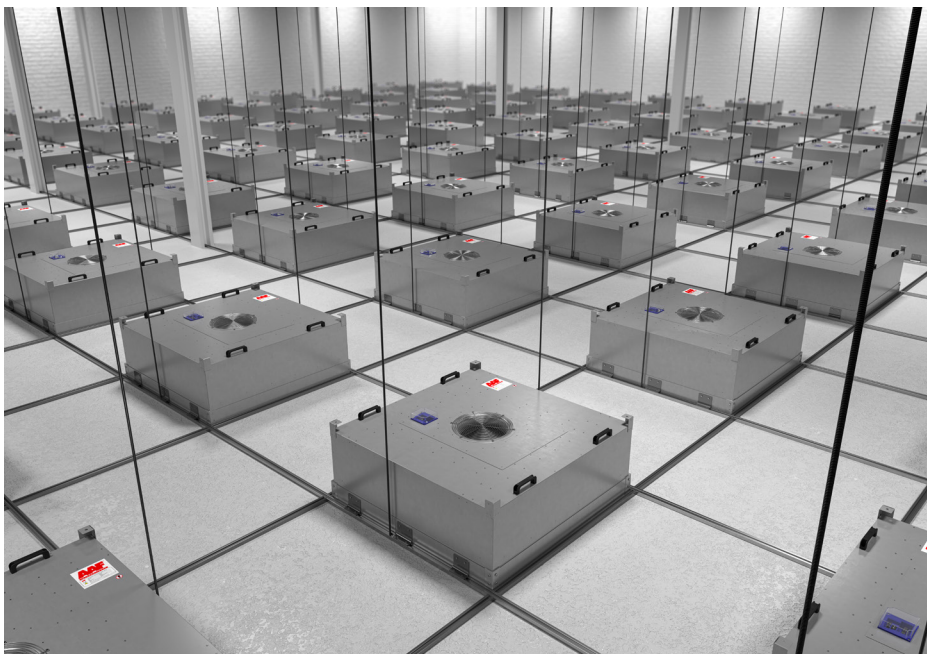

Maximized System Integrity

ASTROFAN CONTROL AND INSTALLATION OPTIONS

Fully integrated Control Systems down to the single FFU

In addition to air filters and non-powered supply housings, certain applications also require unit specific control of the speed and consistency of airflow into large-scale production spaces. Fan Filter Units (FFUs), especially when paired with robust electronic control systems, help to ensure the integrity of production processes within these applications and serve to maximize overall system economy.

Selecting the right FFU depends upon a number of factors, including the degree of airflow control required, the desired level of energy efficiency, filter testing requirements for the space, and accessibility to the filter itself for testing and replacement.

Control System Platform– AstroDrive™

AstroDrive PC, for individual FFU Control software controlled via PC suitable for Modbus or EBM Bus fans including complete architecture to control and retrieve fan information and status.

AstroDrive PLC, control via PLC suitable for Modbus or EBM Bus that can include for room pressures, temperatures, interlock, sensor control.

AstroDrive CCU, control via PLC suitable for EBM Bus that can include for sensor control that can control AstroFan units per group or room.

Fan motor options

AstroFan FFU contains a high performance encapsulated, direct driven, backward curved fan/motor combination. Motor options are available either as EBM BUS or EBM Mod BUS.

The specialized electronic commutation motor design permits speed control through the built-in electronics, e.g. via AstroDrive Control System Platforms.

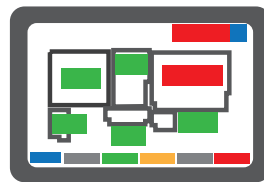

PLC Program Logical Control



PC Smart Control System



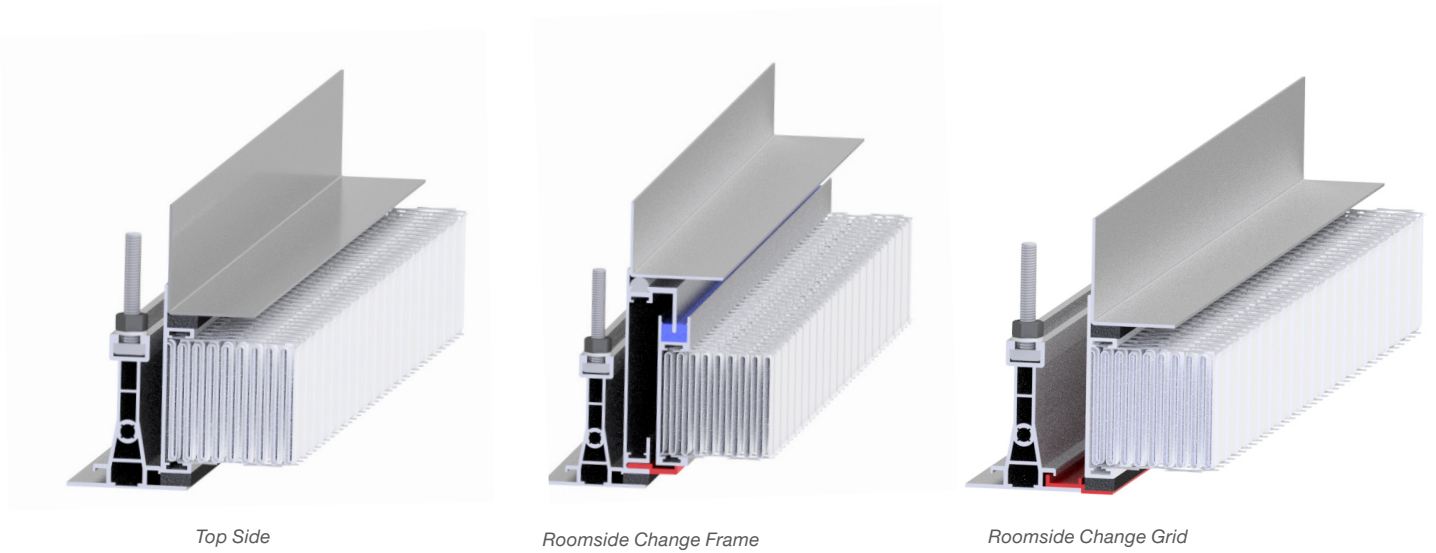

Installation Methods

The AstroFan FFU offers the full range of installation methods from top or roomside. A complete range of adapter frames ensures system integrity.

If the FFU is provided in the room side change option (RSC), then the housing seals and rests on an adapter frame holding the flush mounted filter for room side change provision. The adapter frame rests on the dry gasket, applied into the ceiling grid. Adapter frame and filter have an anodized aluminum cell side extrusion.

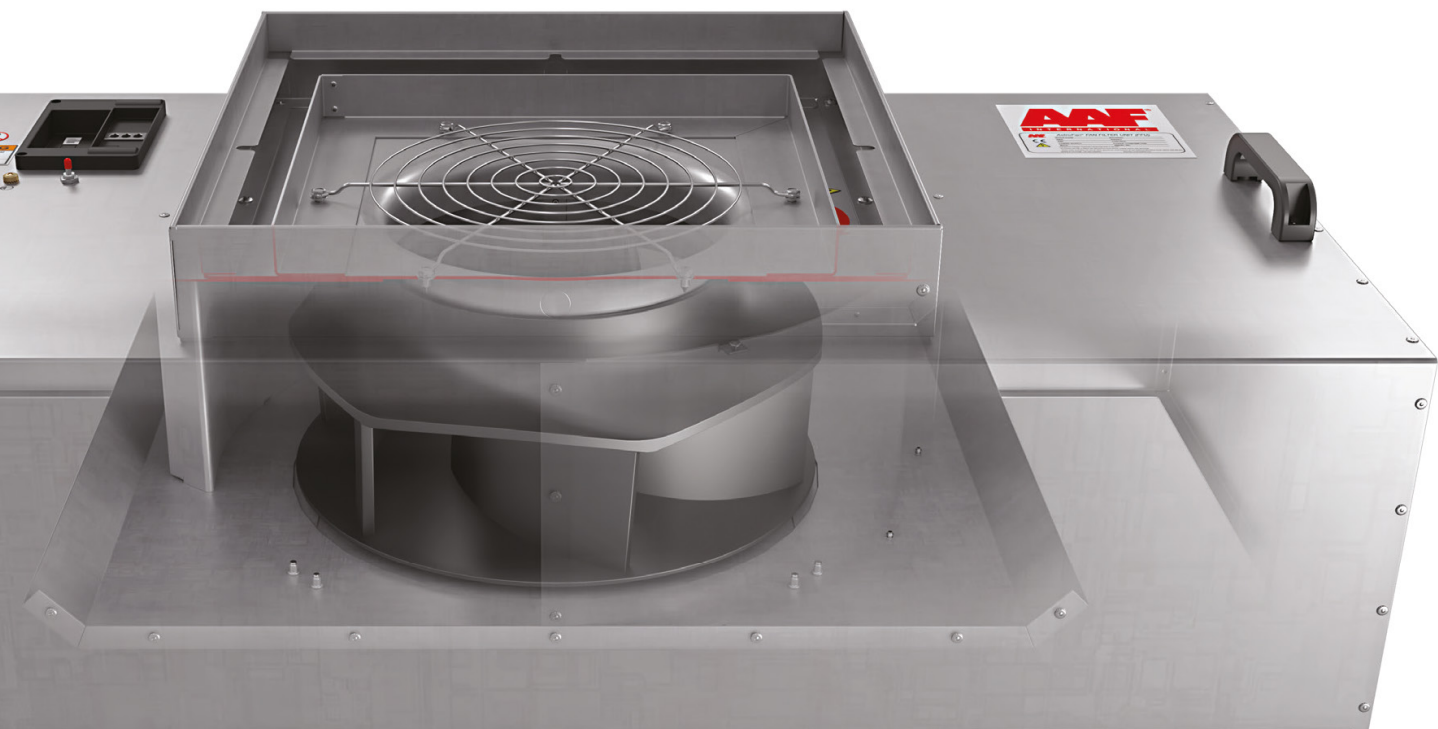

Maximized Filtration Efficiency

ASTROFAN FILTER OPTIONS

Main Filter

The AstroFan FFU is equipped with an AstroCel II HEPA filter in Class H14 as standard. All filters are factory scanned to the European Standard EN1822:2009 to ensure leak free operation.

Additionally the FFUs are suitable for our high performing MEGAcel ME and MEGAcel filters for maximum filter strength, superior resistance against disinfectants and lowest pressure drop.

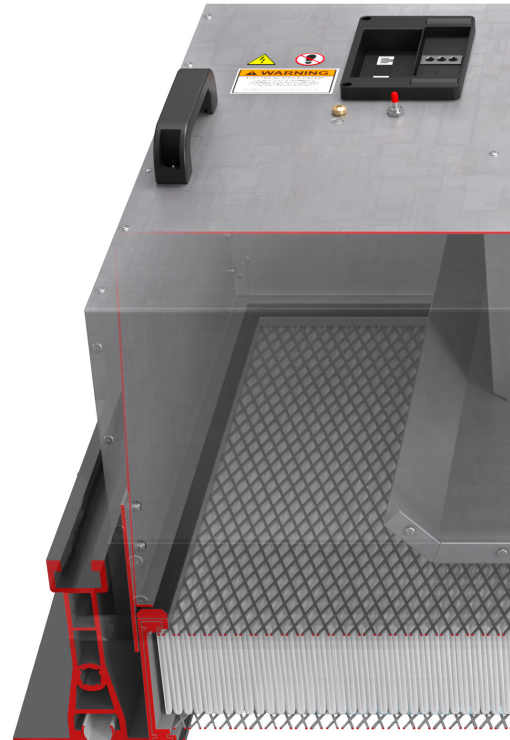

Megacel® II ME

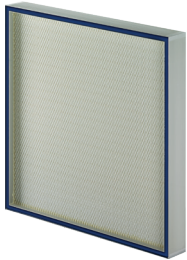

- ePTFE media combines ultra-high efficiency with the lowest possible pressure drop
- High tensile strength and chemically inert ePTFE reduces risk of media damage and degradation
- No boron outgassing
- Compatible with Discrete Particle Counter (DPC) test methods

Megacel® II

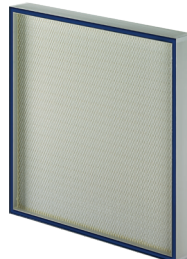

- Dual-layer eFRM media combines ultra-high efficiency and particulate loading with low pressure drop
- High tensile strength and chemically inert eFRM reduces risk of media damage and degradation
- No boron outgassing
- Compatible with Discrete Particle Counter (DPC) and photometric test methods, including high contraction oil-based aerosol testing

AstroCel® II



- Utilizes high performance microglass media to provide high efficiency particulate removal
- Optimally spaced mini-pleat media pack further minimizes pressure drop in this cleanroom panel configuration
- Wide range of efficiencies and pack depth options available
- Compatible with Discrete Particle Counter (DPC) and photometric test methods

Installed Filters

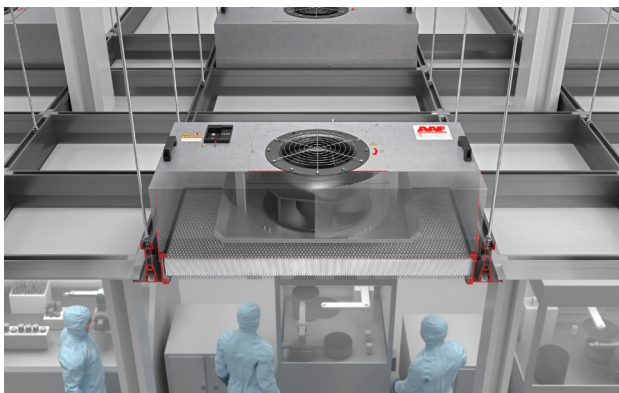

ePTFE Membrane Media for Microelectronics

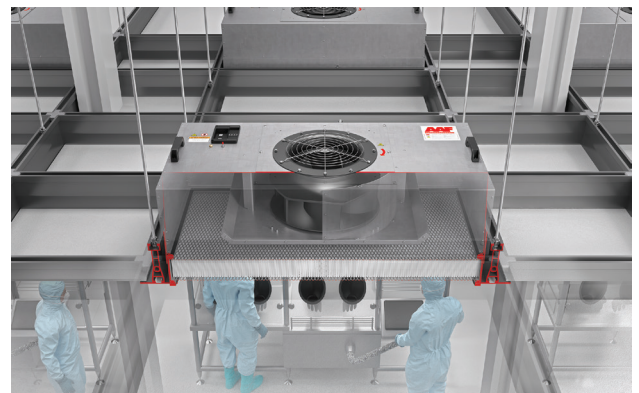

eFRM Membrane Media for Life Sciences

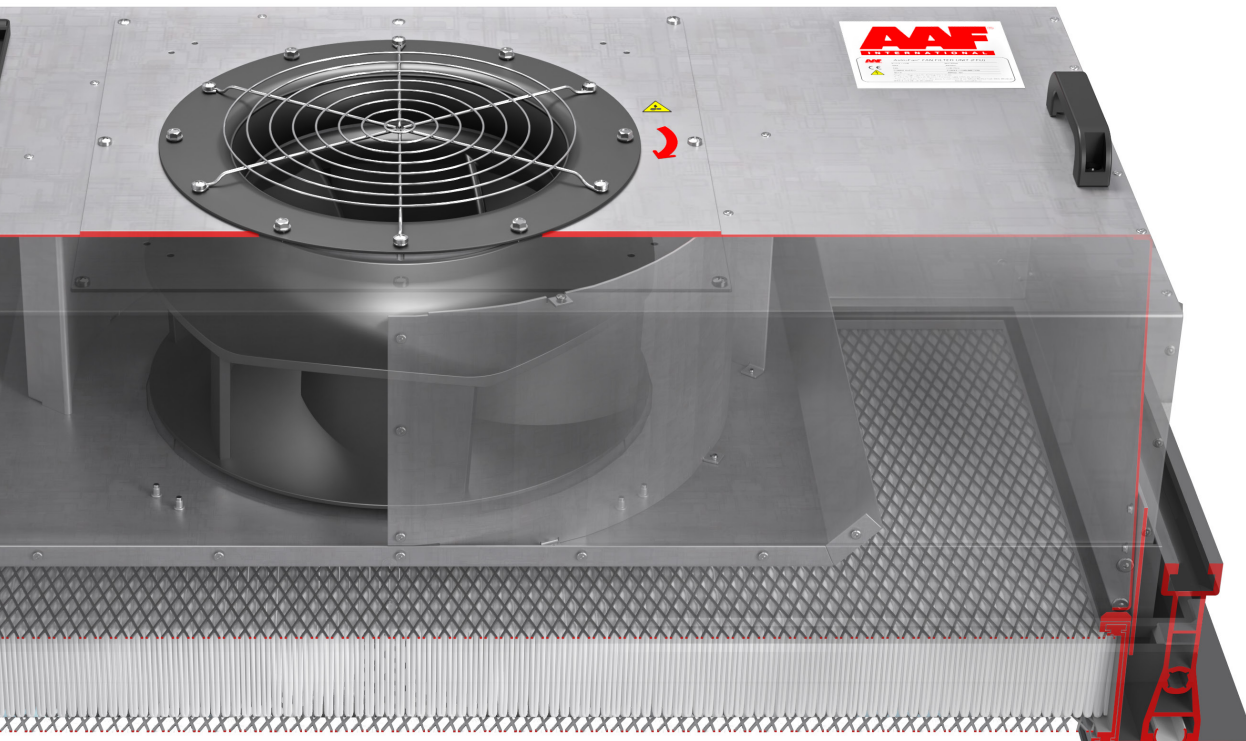

Optional Pre-filter and AMC Filters

Depending on the application sufficient pre-filtration or molecular filtration may be needed.

As an option the AstroFan FFU can be equipped with an adaptor frame to hold Panel or V-bank prefilters as well as single and multiple layer AMC filters.

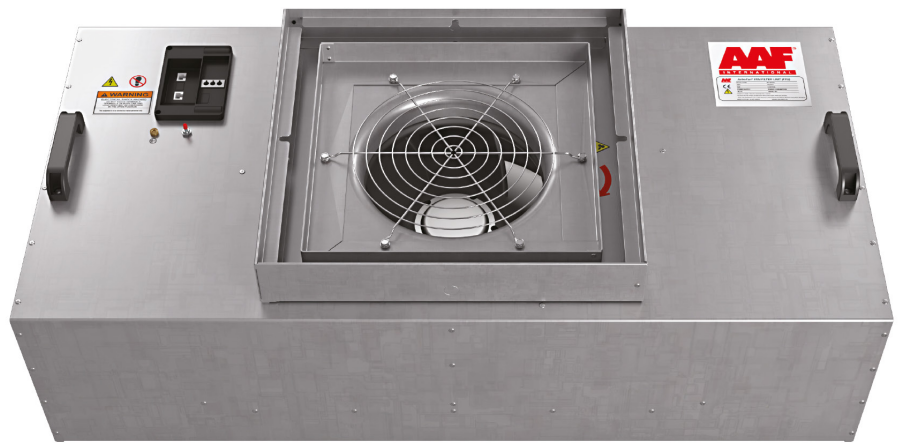

AstroFan FFU with pre-filter adaptor frame

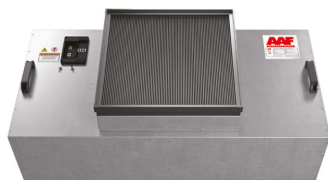

Single layer standard inlet AMC filters

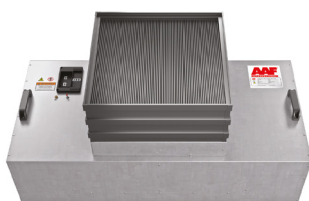

Multiple layer standard inlet AM filters

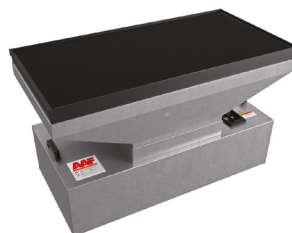

Adaptor plenum for larger AMC filters

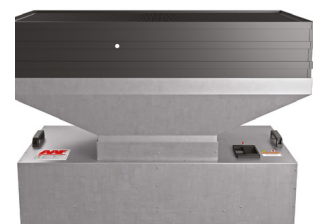

Multiple layer AMC filters WW



AAF International Plant Locations

AAF, the world's largest manufacturer of air filtration solutions, operates production, warehousing and distribution facilities in 22 countries across four continents. With its global headquarters in Louisville, Kentucky, AAF is committed to protecting people, processes and systems through the development and manufacturing of the highest quality air filters, filtration equipment, and associated housing and hardware available today.

Contact your local AAF representative for a complete list of AAF Air Filtration Product Solutions.

Americas

Louisville, KY
Atlanta, GA
Ardmore, OK
Bartow, FL
Columbia, MO
Fayetteville, AR
Hudson, NY
Momence, IL
Ontario, CA
Smithfield, NC
Tijuana, Mexico
Votorantim, Brazil
Washington, NC

Europe

Cramlington, UK
Gasny, France
Vitoria, Spain
Ecoparc, France
Trencin, Slovakia
Olaine, Latvia
Horndal, Sweden
Vantas, Finland

Asia & Middle East

Riyadh, Saudi Arabia
Shah Alam, Malaysia
Suzhou, China
Shenzhen, China
Miaoli, Taiwan
Bangalore, India
Noida, India
Yuki, Japan (Nippon Muki)



AAF International
European Headquarters
Odenwaldstrasse 4, 64646 Heppenheim, Germany
Tel: +49 (0)6252 699 77 0
aafintl.com

AAF International has a policy of continuous product research and improvement and reserves the right to change design and specifications without notice.

©2020 AAF International and its affiliated companies.
PB_303_EN_092020